

# HyApproval

## WP2 – Handbook Compilation

Deliverable 2.2

- PUBLIC -

### APPENDIX VI

#### **Vehicle description and requirements**

Version: 2.0

December 4, 2007

Prepared by:

AIR LIQUIDE DTA

Based on inputs from:

Adam OPEL GmbH

# Table of Contents

1	Description of the tank system .....	3
1.1	Gaseous hydrogen tank .....	3
1.2	Liquid hydrogen tank .....	4
2	Communication with the vehicle.....	5
3	Vehicle safety layer.....	5
4	Grounding.....	5

## Figures

Figure 1: Example of a vehicle’s compressed hydrogen fuel system schematic .....	3
Figure 2: Typical LH2 tank system for vehicles (source: LINDE).....	4

# 1 Description of the tank system

## 1.1 Gaseous hydrogen tank

The following sketch shows an example of a vehicle's compressed hydrogen fuel storage system.

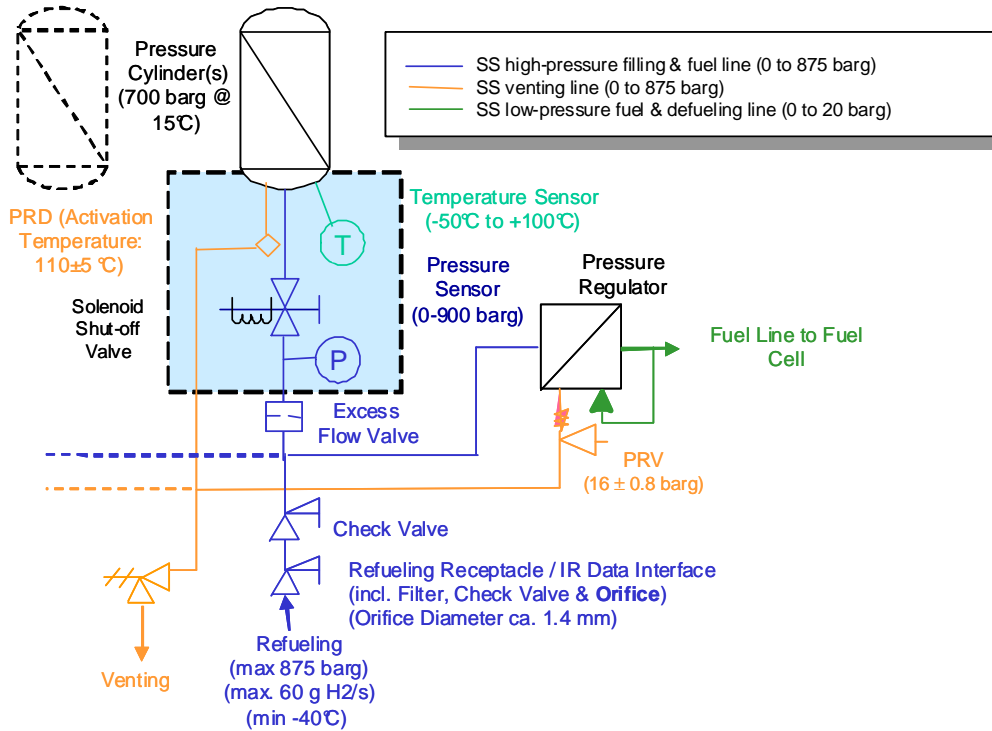

Figure 1: Example of a vehicle's compressed hydrogen fuel system schematic

A temperature-activated, non-reclosing Pressure Relief Device (PRD) is placed in the tank valve unit of each container of the vehicle's fuel system. If the PRD of a hydrogen container activates, the complete hydrogen content of that container will vent. The activation temperature of the PRD is specified by the manufacturer in agreement with the OEMs, e.g. 110±5 °C. The PRD is a safety device for fire events (has no specific functionality during refuelling).

## 1.2 Liquid hydrogen tank

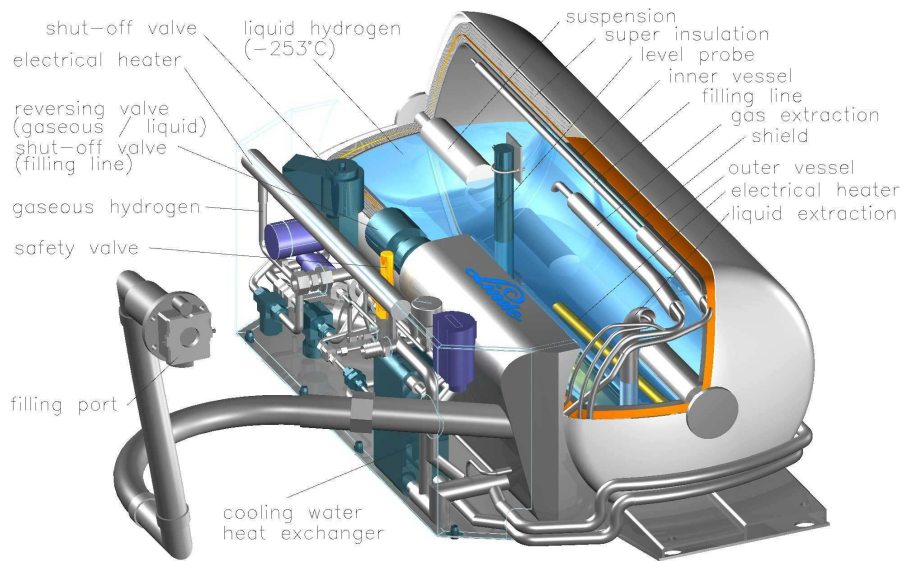

Figure 2: Typical LH2 tank system for vehicles (source: LINDE)

Vehicle LH2 – receptacle:

Receptacles shall comply with all sections of the SAE-TRI 2783.

The failure of any test conducted with the receptacle and nozzle test samples shall constitute a failure of the receptacle design.

In addition, receptacles shall be designed for a life of 5 000 cycles and 15 years with manufacturer specified maintenance.

- a) The receptacle shall be equipped with an internal valve to prevent the escape of gas.
- b) Receptacles shall be designed so that they are either tolerant of solid contamination, or have a means to protect themselves from said contamination when connected or disconnected.
- c) The receptacle shall have provisions to be firmly attached to the vehicle.
- d) The design pressure of the coupling system shall be 1.5 times the MAWP of the inner tank.
- e) The receptacle shall be designed to operate properly with an ambient temperature from  $-40\text{ }^{\circ}\text{C}$  to  $85\text{ }^{\circ}\text{C}$ .

## 2 Communication with the vehicle

Vehicle description:

The vehicle with onboard liquid hydrogen storage has a different receptacle, data interface and fuelling procedure as a vehicle with CGH2 storage system require.

The receptacle and coupling have to handle cryogenic liquid hydrogen flow and cryogenic gaseous hydrogen back flow from the Vehicle Tank system.

At the vehicle side, the data interface consists of contacts that are directly connected to a normal open relay. The relay is located inline of the vehicle safety loop.

## 3 Vehicle safety layer

SAE 2578 specifies the following conditions for permitting refuelling:

- Ignition off
- Pressure difference not less than 1Mpa between HRS and vehicle storage system
- Tank level < 85%
- Park brake engaged
- H2-Sensors in the vehicle showed up no H2-concentration within all compartments in the vehicle

## 4 Grounding

The vehicle homologation shall follow the SAE-J2578 “Recommended Practice for General Fuel Cell Vehicle Safety”.

Static Discharge - The potential for static discharge in areas or compartments containing fuel-bearing equipment should be eliminated by proper bonding and grounding. See SAE J2578 section 4.4.8 for installation of vehicle equipment within areas containing fuel-bearing components.